

SHARK 282

The manual band sawing machine ideal for all the cutting needs of the modern workshop



- **MANUAL SAW**
- **BAND BLADE**
- **FOR +60° CUTTING**

IT IS ALSO AVAILABLE IN THE CCS VERSION (Cutting Control System):

- The CCS device allows to perform single cuts without operator intervention by using the operating head weight controlled by a spring and hydraulic brake.
- The CCS device can be provided as a KIT to install in already manufactured machines.
- By assembling the CCS device, it is possible to order the optional pneumatic vise (the opening/closing of the pneumatic vise is performed by means of a hand operated valve).

CUTTING RANGE

	●	■	▬
0° / mm	250	220	280 x 220
+45° / mm	230	200	220 x 200
+60° / mm	120	80	140 x 80
-45° / mm	200	170	200 x 140
Max. open vice	285 mm		

PERFORMANCE CHARACTERISTICS

Blade size	2950 x 27 x 0.9 mm
Blade speed	36 / 72 m/min
Blade motor	1.5 / 1.8 Kw
Capacity of coolant tank	13 L
Total input power	1.86 Kw

WEIGHT AND DIMENSIONS

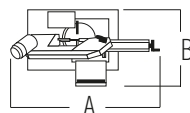
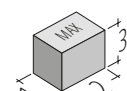
Height of working table	870 mm
Weight	440 kg
	A = 1800 mm
	B = 900 mm
	1 = 1000 mm
	2 = 1700 mm
	3 = 1650 mm